

ServiceLine

The Official Publication of the South Dakota Association of Rural Water Systems

**SDARWS HIRES
NEW WASTEWATER
TECHNICIAN**

MAKE PLANS
TO ATTEND THE
2019 ATC
JANUARY 8-10
PIERRE RAMKOTA

**WATER SYSTEM
TAMPERING**

**NRWA
AWARDS
SDARWS**
for Outstanding
Achievement
in Public Relations



Evolved.

When you pick up a glass of water, you don't usually think about where it comes from. That's how it should be. Smart management of a precious resource. It's second nature at KLJ.

KLJENG.COM



ENGINEERING, REIMAGINED



IN THIS ISSUE



CORPORATE SPONSORS OF SDARWS

Howalt+McDowell Insurance, Inc.

Risk Administration Services

Dakota Pump & Control

Dakota Supply Group

Treatment Resources, Inc.

Banner Associates

Bartlett & West, Inc.

DGR Engineering

Maguire Iron, Inc.

Core and Main

Dakota Pump Inc.

CoBank

Milbank WinWater

AE₂S

- 5** From the SDARWS President
- 7** SDARWS Training Calendar
- 9** SDARWS Staff Directory
- 11** SDARWS Membership Corner
- 13** SDARWS Received Award for Outstanding Achievement in Public Relations
- 14** 2019 Annual Technical Conference Information
- 18** ATC Award Nominations
- 21** The Life of a Circuit Rider: Eating on the Road
- 23** Define Flushable
- 25** Water System Tampering
- 27** WaterPro Conference Highlights
- 29** NRWA Affinity Program: IRIS Mass Notification System
- 31** 2018 Leadership Seminar Agenda
- 32** Photos From the Field
- 33** Certification Questions
- 34** From the Executive Director

ServiceLine is published bi-monthly by the South Dakota Association of Rural Water Systems. The contents of this publication may not be reproduced by any means, in whole or in part, without the prior written consent of SDARWS. SDARWS reserves the right to reject or edit any manuscripts received for publication. All submissions become the property of the South Dakota Association of Rural Water Systems unless otherwise specifically stated in this publication. Statements of fact and opinion are the responsibility of the authors alone and do not imply an opinion on the part of the South Dakota Association of Rural Water Systems. Advertisements and editorials do not represent official policies of the Association. Acceptance of advertising by SDARWS does not constitute endorsement of the advertiser, its products or services, nor does SDARWS make any claims or guarantees as to the accuracy or validity of advertisers' claims.

To submit editorial or advertising content, or to update your mailing information, please contact Jennifer Bame at 605-556-7219 or email jbame@sdarws.com.

SOUTH DAKOTA ASSOCIATION OF RURAL WATER SYSTEMS

P.O. Box 287, Madison, SD 57042 • Phone 605.556.7219, Fax 605.556.1497 • email: info@sdarws.com • www.sdarws.com
Copyright 2018

MILBANK
WinwaterTM
COMPANY

S. Hwy. 15 • P.O. Box 350
Milbank, SD 57252
1-800-743-2972
Fax 605-432-5447

- WATER PRODUCTS
- INDUSTRIAL PIPING
- WATER METER SYSTEMS
- PUMP SYSTEMS
- GEO TEXTILE FABRIC
- ROAD CASTINGS

*Large enough to handle any job,
but small enough to care about yours.*

CITY OF LINOLAKES

KLM

Engineering Inc.
WATER TOWER SPECIALISTS

651-773-5111
www.klmengineering.com

Protecting America's Water
One Tank at a Time



FROM THE SDARWS PRESIDENT

RON GILLEN, SDARWS PRESIDENT

LEADERSHIP SEMINAR

Association staff is busy getting ready for our Annual Leadership Seminar which will be held at the Best Western Ramkota Hotel in Pierre November 14-15th. We have an excellent agenda for this year's seminar - you won't want to miss it! This seminar is geared towards Rural Water System Directors and Board Members and this year's seminar includes sessions on cybersecurity, fiduciary responsibility, parliamentary procedure, a session with the National Rural Water Association on grassroots legislative support. There are also sessions on instilling community trust in your water system and a policy update from Senator John Thune's senior policy advisor Lynn Tjeerdsma. We are excited to announce that Edna Primrose – Rural Development Water and Environment Programs Administrator will be our keynote speaker at the President's Reception. The cost to attend Leadership is \$160, and includes a meal at the President's Reception on the evening of November 14th. Members of WaterPro will receive a \$15 discount. Registration for this event is available on our website at www.sdarws.com, or by calling the SDARWS office at 605-556-7219. The agenda can be found on page 31.

2019 ATC REGISTRATION OPEN

Registration is now open for the 2019 ATC to be held at the Pierre Ramkota January 8-10th. More information can be found on pages 14-17 in this issue of *ServiceLine*.

ATC AWARD SUBMISSIONS

There are only a few more short months before the snow flies, so that means it's time to get in your award nominations for the ATC! Check out the categories on page 18, and get your submissions in before the October 26th deadline.

You can also enter your submissions online at: www.surveymonkey.com/r/ATCawards. If you have questions on awards, please give the Madison office a call at 605-556-7219.

2019 RURAL WATER RALLY

South Dakota Rural Water does many things, and one of the most important benefits to our rural water membership relates to our legislative efforts. Every year the National Rural Water Association hosts a Rural Water Rally in Washington D.C. to further the work of providing drinking water and wastewater services to rural communities. Rural Water professionals, leaders, and customers

from every state attend the rally to thank their Senators and Representatives for their support and encourage them to further support the goals and needs of the Rural Water Industry. The Rally provides your Association the opportunity to meet directly with our congressional delegation one-on-one to discuss concerns of SDARWS members and other systems, as well as with their staffers, and USDA.

We invite you to join us February 4-6, 2019 at the Hyatt Regency on Capitol Hill. For more information, visit NRWA's Rally page at: nrwa.org/rally. Room reservations can be made at the Hyatt Regency by calling 202-737-1234. If you have any questions about attending the Rally, please call the SDARWS office at 605-556-7219. We would love to have you join us on the Hill! ♦

February 4-6, 2019

Washington, DC



Let Your Voice Be Heard!

The Rural Water Rally provides an opportunity for supporters of our industry to make their case directly to their elected officials. Rural Water Associations in each state schedule meetings with Representatives, Senators and their staff, so that they can share the Rural Water success story, answer questions and build important relationships. Attending the Rural Water Rally also provides a unique opportunity to meet with association leaders and watch the Great American Taste Test in person.

For more information, visit:
nrwa.org/rally

Hyatt Regency Capitol Hill
800-332-8715

RALLY



Bridging the gap
between idea +
achievement



Sioux Falls 605.977.7740
Rapid City 605.791.6100

hdrinc.com

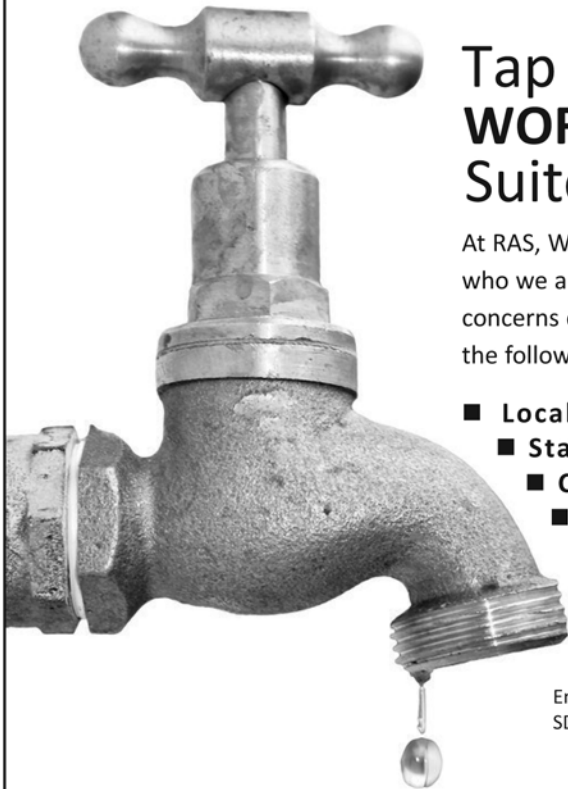

Tap into a **WORKERS' COMPENSATION PROGRAM** Suited for You

At RAS, Workers' Compensation is our primary focus. It's what we do, and who we are. We have the knowledge and experience to address specific concerns or situations. We cover businesses across the spectrum and offer the following services:

- Local Claims and Case Management
- Stay at Work/Return to Work Assistance
- Cost Containment Services
- Loss Prevention and Training

For more information contact our association agency partner,
Jack Miller, Howalt+McDowell Insurance Agency at 800.584.7054.

Endorsed Workers' Compensation carrier for the
SD Rural Water Association for over 10 years.



RISK ADMINISTRATION SERVICES, INC.

WORKERS' COMPENSATION.
Our Focus. Your Opportunity.SM

www.rascompanies.com
1.800.732.1486

Training Calendar

OCTOBER

16 – BASIC WASTEWATER TREATMENT

Rapid City Ramkota
2111 N. LaCrosse Street • Rapid City, SD

This course covers the Association of Boards of Certification “Need to Know” requirements for the Class I & II Wastewater Treatment Exams. This course does not cover the material included in the Stabilization Pond Exam. Operators who will be attempting the Stabilization Pond exam should consider the Stabilization Pond Workshops. Class begins each morning at 8:00 a.m. local time and wraps up around 4:30 p.m. on Tuesday and Wednesday and approximately 11:30 a.m. on Thursday.

30 – STABILIZATION POND WORKSHOP

Aberdeen Ramkota
1400 8th Avenue NW • Aberdeen, SD

This course covers the material on the Association of Boards of Certification Stabilization Pond Exams. It does not cover material on Class I or higher Wastewater Treatment Exams. This is a single day workshop starting at 8:30 a.m. local time and wrapping up around 4:30 p.m.

NOVEMBER

1 – STABILIZATION POND WORKSHOP

Highland Conference Center
2000 Highland Way • Mitchell, SD

This course covers the material on the Association of Boards of Certification Stabilization Pond Exams. It does not cover material on Class I or higher Wastewater Treatment Exams. This is a single day workshop starting at 8:30 a.m. local time and wrapping up around 4:30 p.m.

13-15 – WATER DISTRIBUTION

Sioux Falls Ramkota
3200 W. Maple Street • Sioux Falls, SD

This course covers the Association of Boards of Certification “Need to Know” requirements for the Class I through III Water Distribution Exams. This course only covers the material for Water Distribution. Operations Specialists who wish to attempt a Wastewater Collection Exam should attend the Wastewater Collection Course. Class begins each morning at 8:00 a.m. local time and wraps up around 4:30 p.m. on Tuesday and Wednesday and approximately 11:30 a.m. on Thursday.

DECEMBER

4-6 – WASTEWATER COLLECTION

Sioux Falls Ramkota
3200 W. Maple Street • Sioux Falls, SD

This course covers the Association of Boards of Certification “Need to Know” requirements for the Class I through III Wastewater Distribution Collection Exams. This course only covers the material for Wastewater Collection. Operations Specialists who wish to attempt a Water Distribution Exam should attend the Water Distribution Course. Class begins each morning at 8:00 a.m. local time and wraps up around 4:30 p.m. on Tuesday and Wednesday and approximately 11:30 a.m. on Thursday.

JANUARY

22-24 – BASIC WATER TREATMENT

Spearfish Holiday Inn
305 N. 27th Street • Spearfish, SD

Topics covered include: South Dakota Drinking Water Regulations, disinfection, fluoridation, groundwater and wells, pumping, hardness, cross connections, pH, filtration, turbidity and mathematics. Day 1 & 2, 8:00 a.m. to 4:30 p.m.; Day 3 8:00 a.m. to 11:30 a.m.

FEBRUARY

5-7 – BASIC WASTEWATER TREATMENT

Sioux Falls Ramkota
3200 W. Maple Street • Sioux Falls, SD

This course covers the Association of Boards of Certification “Need to Know” requirements for the Class I & II Wastewater Treatment Exams. This course does not cover the material included in the Stabilization Pond Exam. Operators who will be attempting the Stabilization Pond exam should consider the Stabilization Pond Workshops. Class begins each morning at 8:00 a.m. local time and wraps up around 4:30 p.m. on Tuesday and Wednesday and approximately 11:30 a.m. on Thursday.

26-28 – WATER DISTRIBUTION

Rapid City Ramkota
2111 N. LaCrosse Street • Rapid City, SD

This course covers the Association of Boards of Certification “Need to Know” requirements for the Class I through III Water Distribution Exams. This course only covers the material for Water Distribution. Operations Specialists who wish to attempt a Wastewater Collection Exam should attend the Wastewater Collection Course. Class begins each morning at 8:00 a.m. local time and wraps up around 4:30 p.m. on Tuesday and Wednesday and approximately 11:30 a.m. on Thursday.

MARCH

19-21 – BASIC WASTEWATER TREATMENT

Rapid City Ramkota
2111 N. LaCrosse Street • Rapid City, SD

This course covers the Association of Boards of Certification “Need to Know” requirements for the Class I through III Wastewater Distribution Collection Exams. This course only covers the material for Wastewater Collection. Operations Specialists who wish to attempt a Water Distribution Exam should attend the Water Distribution Course. Class begins each morning at 8:00 a.m. local time and wraps up around 4:30 p.m. on Tuesday and Wednesday and approximately 11:30 a.m. on Thursday.

REGISTER FOR CLASSES ONLINE AT:
go.activecalendar.com/sdarws

Course agendas, maps and registration are all available online at www.sdarws.com. All classes are free unless otherwise noted. For more info on these and other events, visit www.sdarws.com or call 605-556-7219.



engineering
a better
community

water | wastewater

Mni Wasté Water Supply Project | Cheyenne River Sioux Reservation | North Central SD

Brookings | Sioux Falls | Vermillion | Rapid City | Milbank
605.692.6342 | Toll Free 1.855.323.6342
www.bannerassociates.com

BANNER
engineering a better community

DAKOTA PUMP INC.

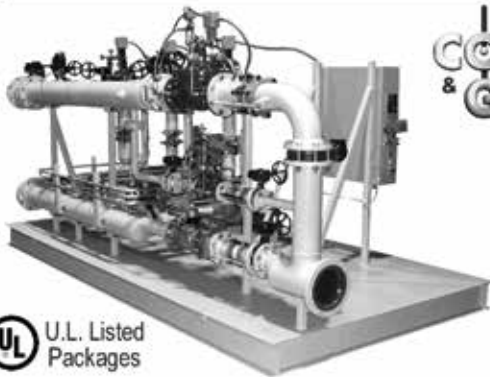

CONNECT
& **GO** Technology

UL U.L. Listed
Packages

Sewage Pump Stations

- Wet Well Mounted Lift Stations
- Flooded Suction Lift Stations
- Self-Priming Lift Stations
- Obround Package Pump Stations



The Total Solution

Water Pump Stations

- Modular Water Booster Stations
- Grade Mounted Water Booster Stations
- Water Booster Pump Stations
- Water Control Vaults

Why Prefabricated?

- Fully factory tested
- Ease of installation
- Simplified design
- Single source responsibility



Dakota Pump Offices:

po box 947 ~ 25524 413th Ave ~ Mitchell, SD 57301 ~
ph.605.996.6636 ~ fax. 605.996.6067 ~ dakotapump.com



SDARWS STAFF DIRECTORY



KURT PFEIFLE

Executive Director

kpfeifle@sdarws.com
605-204-0125



NICK JACKSON

*Technical Assistance
Training Specialist*

njackson@sdarws.com
605-641-4557



JIM ZECK

Training Specialist

jzeck@sdarws.com
605-201-9568



MIKE MOELLER

*Technical Assistance
Training Specialist*

mmoeller@sdarws.com
605-270-4989



STEVE ATTEMA

Training Specialist

sattema@sdarws.com
605-270-1766



BRANT AGER

West River Circuit Rider

bager@sdarws.com
605-641-1923



JEREMIAH CORBIN

*Source Water Protection
Specialist*

jcorbin@sdarws.com
605-270-3894



GREG GROSS

East River Circuit Rider

ggross@sdarws.com
605-201-6026



ROBYN BROTHERS

Office Manager

rbrothers@sdarws.com
605-556-7219



JEFF FOSSUM

East River Circuit Rider

jfossu@sdarws.com
605-201-9561



JENNIFER BAME

*Communications &
Marketing Coordinator*

jbame@sdarws.com
605-556-7219



BILL THORSON

*East River Wastewater
Technician*

bthorson@sdarws.com
605-201-0170



ABBEY LARSON

*West River Wastewater
Technician*

alarson@sdarws.com
605-645-6488

SPN & ASSOCIATES

ENGINEERS SURVEYORS GIS SERVICES

Schmucker, Paul, Nohr and Associates

2100 N. Sanborn Blvd – PO Box 398
 Mitchell, SD 57301
 Phone (605) 996-7761
 FAX (605) 996-0015
 www.spn-assoc.com

Water • Wastewater • Storm Water • Streets
 Airports • Solid Waste • Animal Waste
 Land Surveying • Site Development
 Geographic Information Systems (GIS)



**ENGINEERING EXCELLENCE
 SINCE 1961**

Chemicals, Equipment and Service for
Safe, Clean Water



www.hawkinsinc.com

Water Treatment

- Potable Water
- Raw Water Clarification
- Swimming Pools
- Boiler & Cooling Systems
- Wastewater
- Waste De-Watering
- Waste Settling Aids
- Collection Systems

Equipment:

- Chemical Injection Pumps
- Control and Monitoring Systems
- Chlorination Control Systems
- Chemical Feed Equipment

Black Hawk, SD
 605.787.6881

Fargo, ND
 701.293.9618

Sioux Falls, SD
 605.368.5793

Washburn, ND
 701.462.8588

SDARWS MEMBERSHIP CORNER



LIKE US ON FACEBOOK
@SDRuralWater
to see event pictures
and updates on SDARWS

WE LOVE GETTING MAIL!

Please send us your letters of support!

The hard work of dedicated SDARWS employees helps South Dakota's rural water and wastewater systems to have safe, reliable and quality water. SDARWS asks for your letters of appreciation in return for our on-site assistance. These letters are used to help obtain funding to continue these programs.

Please submit letters via email to: info@sdarws.com **or by mail to:** South Dakota Rural Water, PO Box 287, Madison, SD 57042

ARE YOU ON OUR EMAIL LIST?

Don't miss out on event details, training updates, job postings and other important information!

Email info@sdarws.com to be added to our list.

ARTICLE SUBMISSIONS

Does your company have information to share that would be of value to our readership? If so, we would welcome your article submission for ServiceLine Magazine.

To send us an article, please email: jbame@sdarws.com

NOTE: SDARWS reserves the right to refuse any and all article requests.

A NOTE OF THANKS

On Friday, August 10, I contacted Circuit Rider Brant Ager with a situation that came about within our city of Murdo. Me knowing of the equipment that is owned by SDARWS he was able to come to my rescue. We are presently working on a street project (curb & gutter, storm drain, concrete paving, and sidewalks). A lot of the town is under construction, and the unforeseen always happens. At one of the intersections, we found a main valve that was inoperable. Two people with 6-foot cheaters could NOT operate the valve. I got in touch with Brant, and he was able to come to Murdo with the hydraulic valve operator that is on the Kubota side by side. I was amazed at the operation of this equipment. With the street project and not having to dig and replace a valve repair clamps and not having to do with any change orders with the contractors the savings estimated at \$4,000 to \$5,000.

With all that being said HATS OFF TO Brant Ager, he came through with flying colors.

Thanks For All You Do!

Ray Erikson
W/W Supt.
City of Murdo



Have a complex
water treatment project?
We can help.

Treatment Resources' fifty years of combined experience in water treatment makes us uniquely qualified to meet your objectives. We represent the finest manufacturers in the industry and have worked with hundreds of municipalities and their consulting engineers to solve their water treatment problems. For more information visit us online or call us at (651) 702-2692.



800-211-6432
www.electricpump.com

115 Lipton Street
Suite B
Tea, SD 57064

402-333-9660
www.mc2h2o.com

SDARWS Receives Award for Outstanding Achievement in Public Relations

The South Dakota Association of Rural Water Systems won the award for Outstanding Achievement in Communications, Publications and Public Relations award at the annual Tribute to Excellence awards ceremony, held on Sept. 19 at the WaterPro Conference in Fort Worth, Texas.

“In addition to their quarterly magazine (*ServiceLine*), South Dakota also publishes a consumer magazine (*Quality on Tap!*) and three digital newsletters that create a unified voice for rural water in their state,” Fulgham said. “Their newly re-designed website features an interactive map of rural water systems, online class and event registration, digital magazines, services and fees, live Facebook and Twitter feeds, as well as history, staff contacts, and promote NRWA Affinity Programs.”

SDARWS is the only Rural Water Association in the nation who produces a consumer magazine. “*Quality on Tap!*” is published quarterly along with 17 participating Rural Water Systems, and is created in-house. 34,000 copies are mailed quarterly, and reach about half of our rural water consumers in South Dakota. “*QOT*” highlights water issues affecting consumers, and proves successful in creating a unified voice for rural water in our state. Other publications produced by SDARWS include *ServiceLine* magazine, *Rural Water Bi-Monthly eNews*, *JobConnection eNewsletter*, and *Ripples Legislative eNewsletter*.

SDARWS’ public relations efforts are administered by our Communications and Marketing Coordinator Jennifer Bame. Jennifer is a graduate of South Dakota State University, with a B.A. in Journalism/Mass Communications, and has been with SDARWS since 2012. The Association also received this award in 2016, and was awarded State Association of the Year in 2017.

The 2018 WaterPro Conference was held September 17-19 in Fort Worth, Texas. The opening included speeches from NRWA President Steve Fletcher, Assistant to the Secretary for Rural Development at the United States Department of Agriculture Anne Hazlett, and NRWA CEO Sam Wade.

56 South Dakotans traveled to WaterPro and were treated to educational sessions on new water technologies, operations and management, and an exhibit hall full of useful tools and services. WaterPro is the annual conference of the National Rural Water Association and is designed to bring together water and wastewater utility systems – large and small, municipal and rural – for sessions in operations, management, boardsmanship and governance.

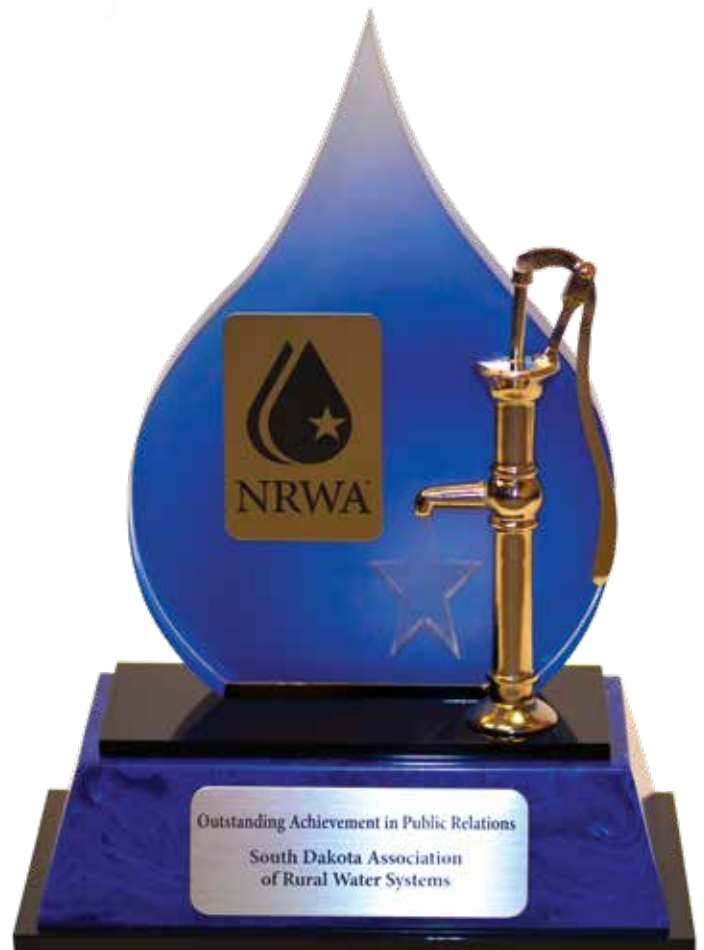

ATC 2019

SOUTH DAKOTA RURAL WATER'S ANNUAL TECHNICAL CONFERENCE

JANUARY 8-10, 2019

Pierre Ramkota Hotel & Convention Center

REGISTER

Register by December 14, 2018 and save \$25 off your registration or \$50 off your booth. You can register through a link on our website at www.sdarws.com/annual-conference

WATERPRO DISCOUNT

Become a WaterPro member and save an extra \$30 on your 2019 ATC registration. In addition to \$30 off at the ATC, you will also receive \$10 off 2019 West River EXPO registration, as well as discounts on several NRWA events. Visit waterprocommunity.org to register for a WaterPro membership.

CLIENT MEETING ROOMS

We have a limited number of rooms available for client meetings. Call 605-556-7219 to reserve.

HOTEL INFORMATION

DAYS INN – 605-224-0411

GOVERNOR'S INN – 605-224-4200

HOLIDAY INN EXPRESS – 605-223-9045

BAYMONT INN & SUITES – 605-224-4140

PREMIER
ATC SPONSOR



EDUCATIONAL
SESSIONS SPONSOR

Bartlett & West

AWARDS BRUNCH
SPONSOR

DGR
ENGINEERING

www.sdarws.com/annual-conference.html

PRELIMINARY SCHEDULE

REGISTRATION HOURS

Tuesday, 1-8 8:00 AM - 4:30 PM

Wednesday, 1-9 8:00 AM - 4:30 PM

OPENING SESSION & KEYNOTE

Sponsored by AE2S

Tuesday, 1-8 1:00 PM - 2:30 PM

KEYNOTE BREAKOUT

Sponsored by AE2S

Tuesday, 1-8 3:00 PM - 4:30 PM

44th ANNUAL MEETING

Wednesday, 1-9 8:00 AM - 10:00 AM

RURAL WATER CENTER ANNUAL MEETING

Wednesday, 1-9 10:00 AM - 11:00 AM

LEGISLATIVE PANEL

Wednesday, 1-9 1:00 PM - 2:30 PM

HALLWAY EXHIBITS

Tuesday, 1-8 10:00 AM - 5:00 PM

Wednesday, 1-9 8:00 AM - 8:00 PM

EXHIBIT HALL & LEGISLATIVE RECEPTION

Wednesday, 1-9 4:00 PM - 8:00 PM

LEGISLATIVE OPEN FORUM

Thursday, 1-10 8:00 AM - 9:00 AM

AWARDS BRUNCH

Sponsored by DGR

Thursday, 1-10 9:30 AM - 11:00 AM

SPONSORSHIPS AVAILABLE

EDUCATIONAL SESSIONS SPONSOR – \$2,500

Benefits include recognition in conference displays and banners, logo displayed in session rooms, recognition in program booklet. Sponsorship price includes a booth space in the Exhibit Hall Wednesday night, as well as Full Conference Registration for two individuals.

BREAK TABLE SPONSORSHIP – \$1,200

Sponsorship includes electronic signage at the break table, the opportunity to place promo materials on the break table, and recognition in the program booklet and agenda displays.

NEW! CHARGING STATION SPONSORSHIP – \$1,000

Sponsor the electronics charging station. Charging station will be up for the entire duration of the conference (3 days), and includes advertising space for a printed 22" x 28" ad on two sides of the station. You can either send us an ad, or we will print your logo in the space allotted.

CONFERENCE LANYARD SPONSOR – \$500-\$1,500

Place your company's logo around every conference attendee with their name badge. Note: If you wish to supply your own lanyards, the sponsorship is only \$500.

CONFERENCE BAG SPONSOR – \$600

Your branded bag will be handed out to every conference attendee with their name badge and agenda booklet at registration. Price includes bag.

KEG SPONSORSHIP – \$500

Want extra exposure in the Exhibit Hall? Sponsor a keg! Keg can be placed in your booth if desired. Includes signage.

T-SHIRT SPONSORSHIP – \$150

For only \$150, your company's logo will be printed on the back of this year's ATC t-shirt which will be handed out free to every conference attendee. Artwork deadline is December 1st.

PUT YOUR SWAG IN OUR BAG – \$100

Have your postcard (or company brochure, flyer, pen, notepad, flash drive, etc) inserted into each conference attendee's bag. Price is for 400 items which must be delivered to our Madison office by December 15th.

PROGRAM BOOKLET ADS

Put your ad in our program booklet to be handed out to each attendee. Ad deadline is December 1st.

\$300 – Full Page Color \$175 – Full Page B&W

\$125 – 1/4 Page Color \$75 – 1/4 Page B&W

Sponsorships can be reserved online with ATC booth registration, by calling Jennifer at 605-556-7219 or via email at atc@sdarws.com. Sponsorships subject to availability.

ATTENDEE INFORMATION

MEMBER FULL REGISTRATION

\$250 (Standard)

\$220 (WaterPro Discount Standard)

\$225 (Early Bird - by 12.14.18)

\$195 (WaterPro Discount + Early Bird)

MEMBER FULL + SPOUSE

\$295 (Standard)

\$265 (WaterPro Discount Standard)

\$270 (Early Bird - by 12.14.18)

\$240 (WaterPro Discount + Early Bird)

MEMBER TUESDAY ONLY

\$155 (Standard)

\$125 (WaterPro Discount Standard)

\$130 (Early Bird - by 12.14.18)

\$100 (WaterPro Discount + Early Bird)

MEMBER WEDNESDAY ONLY

\$205 (Standard)

\$175 (WaterPro Discount Standard)

\$180 (Early Bird - by 12.14.18)

\$150 (WaterPro Discount + Early Bird)

MEMBER BRUNCH ONLY

\$30 (Standard)

WANT TO SAVE \$30 ON YOUR ATC REGISTRATION? BECOME A MEMBER OF THE WATERPRO ONLINE COMMUNITY!

THE WATERPRO ONLINE COMMUNITY offers significant networking and professional advancement opportunities for NRWA members. The WaterPro OLC will allow you to network with utility personnel, access training on new technology and regulations, discuss utility-specific topics with your peers, and even manage your membership online.

Subscription to the Rural Water magazine – NRWA's award-winning quarterly publication has articles, legislative updates, commentaries and other timely information on local, state, national and world events. Individual membership is only \$49!

IN ADDITION TO \$30 OFF AT THE ATC, GET \$10 OFF AT THE 2019 WEST RIVER EXPO, AND \$10 OFF LEADERSHIP TRAINING!

As a member of WaterPro, you also become an individual member of the National Rural Water Association (NRWA)

As a NRWA Individual Member, you will receive the following benefits designed to strengthen your network with utilities and professionals in the water and wastewater industry:

- Discounts on merchandise at the Rural Water Store, WaterPro Conference and online
- Access to the latest information on technology, regulation and funding through Water University webinars
- NRWA Membership lapel pin, certificate and wallet card
- Support funding for water and wastewater utilities – NRWA is a leading advocate for infrastructure funding, resulting in billions of dollars of funding
- Timely information on the impact your support is having throughout the water industry
- Verizon Wireless – Access to top tier discounts
- LifeLock Identity Theft Protection – Receive 30 Days Free + 10% off for the lifetime of your membership.

To learn more, please visit www.waterprocommunity.org/r/us/

EXHIBITOR INFORMATION

EXHIBIT HALL – \$425

- Exhibit in our Exhibit Hall/Legislative Reception on Wednesday evening from 4-8pm
- Booth registration includes full conference registration for two individuals

Setup: Wednesday, January 8th – 9:30am - 1:30pm

Exhibit: Wednesday, January 8th – 4:00pm - 8:00pm

Tear Down: Wednesday, January 8th – 8:15pm - 9:00pm

FULL CONFERENCE HALLWAY – \$525

- Exhibit for the entire duration of the ATC (Tuesday, January 8th, and Wednesday, January 9th)

- Booth registration includes full conference registration for two individuals
- Booth will be assigned in the hallway area of the Ramkota Convention Center.

Setup: Tuesday, January 8th – 8:00am - 10:00am

Exhibit: Tuesday, January 8th – 10:00am - 5:00pm;
Wednesday, January 9th – 7:30am - 8:00pm

Tear Down: Wednesday, January 9th – 8:15pm - 9:00pm

Additional exhibit personnel will need to register as an attendee. All booth spaces are 8-foot wide and contain electricity, a table, and two chairs. You must be a current member of South Dakota Rural Water to reserve a booth. All registrations will be reviewed.

Rob Bell

2019 ATC KEYNOTE SPEAKER



Rob Bell is the perfect combination of educational know-how, professional experience and humor for a speaker. His presentations are high-energy and feature real-life anecdotes, which are as fun as they are meaningful. Drawing on more than 25 years of experience in leadership roles, customer service, and training, Rob makes it simple, clear and FUN to improve customer service and gain leadership skills.

Rob began teaching his Customer Service and Communication Techniques early in his tenure as the Personnel Development - Education & Training Director for Dick's Supermarkets, Inc. He is "a recovering CPA" who worked as the Accounting Manager for a large transportation company before becoming Dick's Supermarkets' go-to guy for education. He has also worked as an auditor, and an adjunct instructor at the University of Wisconsin - Platteville.

Rob has earned the prestigious designation of Certified Speaking Professional (which has been awarded to less than 650 people in the world). Rob was the 2011 - 2012 president of the National Speakers Association - Wisconsin Chapter as well as the author of the book, "Beyond Paper or Plastic - 8 Items or Less to Remarkable Service."

His insight on both external and internal customer service rings true to all who hear him. Participants leave Rob's presentations "fired up" and supplied with the techniques they need to meet and exceed customer and organization expectations. He is truly the Bell you will want to "ring for service."

SEE ROB LIVE!
TUESDAY, JANUARY 8TH
AMPHITHEATER II
KEYNOTE: 1:00 PM
BREAKOUT: 3:00 PM



SPOUSE PROGRAM

This year's craft is a 12x12 painted stenciled sign on wood. There are several options to choose from. Spouses registered before December 7th will have the option to choose which sign design they want to make.

SPOUSE PROGRAM SCHEDULE

Wednesday, January 9

Continental Breakfast	9:00 AM
Craft time with Jennifer	10:00 AM
Soup/Sandwich Luncheon	11:00 AM

DOES YOUR
SYSTEM HAVE
THE BEST
DRINKING WATER
IN SOUTH
DAKOTA

Bring a glass quart jar of your water to the 44th Annual Technical Conference in Pierre

All entries must be submitted to the registration desk by 2:00 pm on January 9th in order to be entered into the contest. Entries must be submitted in a glass jar. A representative from each system submitting an entry must be in attendance; no person can represent more than one entry.

The winner's name will be announced at the ATC Awards Banquet on Thursday, January 10, 2019. The winner will go on to represent South Dakota at the NRWA Great American Water Taste Test in Washington, DC on February 7th, 2019.

South Dakota Rural Water AWARD NOMINATIONS

Do you know someone who is doing a great job? Goes above and beyond the call of duty? Has your water system achieved excellence this year – or has overcome some amazing challenges?

Give recognition where it is due by completing our Awards Nomination Form. Awards will be presented at the Awards Brunch at the ATC – January 10, 2019. **Application deadline is October 26, 2018.** Eligible nominees must be affiliated with a system member in good standing. The online form can be found at www.surveymonkey.com/r/ATCAwards, or through a link on our website at: www.sdarws.com/annual-conference.html.

WE ARE ACCEPTING NOMINATIONS FOR THE FOLLOWING CATEGORIES:

RURAL WATER SYSTEM OF THE YEAR: a member system who puts forth exceptional efforts to properly manage, operate, and maintain their drinking water system.

RURAL WATER MANAGER OF THE YEAR: Recognition for a manager of a Rural Water System for outstanding performance in operating a Rural Water System.

RURAL WATER OFFICE PERSON OF THE YEAR: Recognition for an administrative employee of a Rural Water System for outstanding performance in office management and procedures.

RURAL WATER SYSTEM OPERATIONS SUPERVISOR OF THE YEAR: Recognition for a State of South Dakota Certified Operator who is actively working a supervisory role for a Rural Water System, and has demonstrated outstanding leadership ability and/or accomplishments in drinking water.

RURAL WATER SYSTEM OPERATIONS SPECIALIST OF THE YEAR: Recognition for a State of South Dakota Certified Operator who is actively working for a Rural Water System with outstanding leadership ability and/or accomplishments in drinking water.

MUNICIPAL WATER/WASTEWATER SYSTEM OF THE YEAR: a municipality who puts forth exceptional efforts to properly manage, operate, and maintain their drinking water and wastewater system.

MUNICIPAL MANAGER OF THE YEAR: Recognition for a municipal manager for outstanding performance in managing a municipality.

MUNICIPAL OFFICE PERSON OF THE YEAR: Recognition for an administrative employee of a municipality (i.e. clerk, finance officer, etc.) for outstanding performance in office management and procedures.

MUNICIPAL OPERATIONS SPECIALIST OF THE YEAR: Recognition for a State of South Dakota Certified Operator who is actively working for a municipality with outstanding leadership ability/accomplishments in water.

CARROLL ANDERSON MEMORIAL: The Carroll Anderson Memorial Award is a tribute to the exemplary work of Carroll Anderson who gave generously of his time, talents, and efforts to the Kingbrook Rural Water System and the South Dakota Association of Rural Water Systems. This award recognizes an individual's outstanding voluntary contributions to the advancement of rural community water systems in South Dakota, and is the greatest tribute the Association can bestow recognizing an individual's contributions to both the member system and to SDARWS.

FRIEND OF RURAL WATER: This distinguished honor is awarded to agencies, organizations, or individuals who have lent a hand in supporting this fantastic phenomenon we call Rural Water. The ability to provide life's essential need, water, to all the citizens of South Dakota was not done by one person or organization; it is a collective effort encompassing many.

SPIRIT OF RURAL WATER: This award is presented to an individual, business or group that goes above and beyond for a rural water system or rural water cause. South Dakota Rural Water wants to recognize exceptional rural water advocates that stand out from the pack because of their commitment to rural water issues and/or their passion for the job. Eligible candidates include rural and community water consumers, employees, directors, as well as lawmakers, businesses, or any person or group that puts forth a noble effort to advance rural water.

DONALD B. POSPISHIL: This award honors the work of Don Pospishil who dedicated many years of his life to helping small water systems across South Dakota. The Donald B. Pospishil Award is awarded to individuals who demonstrate leadership abilities in the water supply field, provide quality services to consumers, and exhibits professionalism and dedication while operating and maintaining a small water system.

South Dakota Rural Water 2018 AWARDS NOMINATION FORM

This form is also available online at: www.surveymonkey.com/r/ATCawards
or through a link on our website at: www.sdarws.com/annual-conference.html

Name of Nominee _____ Title _____

Employer _____ Years with System _____

Name of person making nomination _____

Address _____

City _____ State _____ Zipcode _____

PLEASE INDICATE AWARD:

- | | |
|--|--|
| <input type="checkbox"/> Rural Water System of the Year | <input type="checkbox"/> Municipal Office Person of the Year |
| <input type="checkbox"/> Rural Water Manager of the Year | <input type="checkbox"/> Municipal Operations Specialist of the Year |
| <input type="checkbox"/> Rural Water Office Person of the Year | <input type="checkbox"/> Carroll Anderson Memorial |
| <input type="checkbox"/> Rural Water Operations Supervisor of the Year | <input type="checkbox"/> Friend of Rural Water |
| <input type="checkbox"/> Rural Water Operations Specialist of the Year | <input type="checkbox"/> Spirit of Rural Water |
| <input type="checkbox"/> Municipal Water/Wastewater System of the Year | <input type="checkbox"/> Donald B. Pospishil |
| <input type="checkbox"/> Municipal Manager of the Year | |

SUPPORTING INFORMATION: Please provide a narrative for why this nominee deserves the award. (Outstanding accomplishments, contributions to system and state association, certifications, awards, exemplary work on legislative issues, leadership, civic activities, etc.) Feel free to add additional pages if needed.

DEADLINE TO APPLY IS OCTOBER 26, 2018

Please complete this entry form and mail to:
SDARWS | Attn: Jeremiah | PO Box 287 | Madison, SD 57042
or scan and email to atc@sdarws.com

Form is also available online at: www.surveymonkey.com/r/ATCawards
or on our website at: www.sdarws.com/annual-conference.html

MAKE YOUR WATER TANK LAST...

LET MAGUIRE IRON HELP EXTEND THE LIFE SPAN OF YOUR TANK AND INFRASTRUCTURE.

- Maintenance Contracts
- Interior & Exterior Paint and Repair
- Tank Mixing Systems
- Chemical Cleaning
- Component Replacement

READY TO REPLACE? MAGUIRE IRON ALSO DESIGNS, FABRICATES AND ERECTS NEW TANKS.

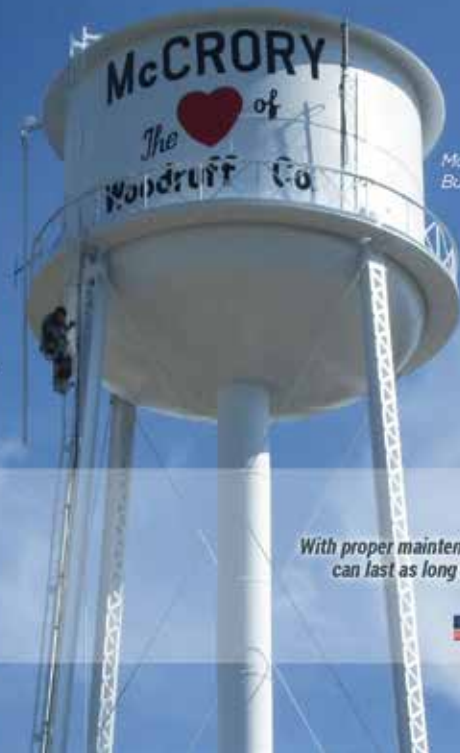

McCrory, AR
Built 1936



MAGUIREIRON.COM | 605 334-9749
WATER TOWER SPECIALISTS SINCE 1915

With proper maintenance, tanks can last as long as we have!



Bringing

Quality Water

to Rural America for over 60 Years

Drinking Water

- Supply
- Treatment
- Storage
- Distribution

Wastewater

- Treatment
- Collection
- Lift Stations
- Sewer Rehab

DGR
ENGINEERING

Sioux Falls & Yankton, SD
Rock Rapids, Sioux City
& Ankeny, IA

800-446-2531

Trusted. Professional. Solutions.

Look for Kingbrook Rural Water's project, featured in our fall newsletter at dgr.com

dgr.com



THE LIFE OF A CIRCUIT RIDER EATING ON THE ROAD



**By Greg Gross,
SDARWS Circuit Rider**

Food is a well-understood word, but for me, it is also an acronym. F.O.O.D. to me means “Finding Original Outstanding Dining.” Fredrick the Great, and Napoleon were both given credit for the quote “An army marches on its stomach.” The Army of Circuit Riders across the country spends much of their life on the road, away from home and good home cooking. F.O.O.D. becomes part of the daily challenge for every extended traveler. Nothing can spoil your day more than stopping for a break only to overpay for sub-par cuisine. The local town residences can always point you to the best food in the area, but sometimes there is only one choice or no choice at all. In my limited experience, a good sign is the number of cars parked around the local café or eatery. On one occasion I spotted a café that looked like every car in town was parked there. This had to be the best spot to eat. After entering the almost empty building, I soon learned that the back room was the meeting place for the Red Hat Ladies and had nothing to do with the food. It took forever for the one server to serve, but the tables, run the cash register and chit-chat with all the locals. Good food, but I didn’t have time in my day for an hour lunch break.

I have never been much of a food snob, but really, how many greasy burgers can you

swallow before you say “I want something good to eat.” Good food not only makes you feel full, but it also doesn’t come back to haunt you (onion rings).

I would like to share some of my favorite hidden treasures from the road. My last outing in Watertown took me off the beaten path by accident to Page’s Place – a great homemade meal at a great price. I hope to make future recommendations for some of my favorite feeding troughs.

In conclusion, to quote Julia Child, “The only time to eat diet food is while you’re waiting for the steak to cook.” Till we eat again! ♣





Local Service, Nationwide

2101 East 54th St. North • P.O. Box 85439
Phone: 605/339-2814 • FAX: 605/339-2632
Sioux Falls, South Dakota 57118-5439

2808 East Highway 44
Phone 605/716-9427 • Fax 605/716-9447
Rapid City, South Dakota 57703

CALL TOLL-FREE: 800-843-3799

coreandmain.com

- SENSUS - Water Meters
- EBAA Joint Restraints
- Neenah Castings
- Locators
- Link Seals
- Watts Valves
- Plug & Butterfly Valves
- Cretex Specialty Products
- PVC Pipe & Fittings
- AFC Valves & Hydrants
- Ladtech HDPE Adjusting Rings
- Victualic Couplings
- Ford Brass & Pipe Products
- Ductile Iron Pipe & Fittings
- Automatic Control Valves
- Flanged Piping
- Copper Tubing
- HDPE Pipe & Manholes
- Air Release & Check Valves
- Contech Construction Products
- Pipe Repair Products
- Valve Box Centering Adapters



Bailey Special Risks, Inc.

Data Breach Insurance for Utilities

Bailey Special Risks, Inc. proudly offers Beazley Breach Response insurance.

This unique insurance provides a comprehensive service that protects utilities that have suffered a data breach with notification, loss control, credit monitoring services, and more.

563 million
records reported leaked

since Privacy Rights Clearinghouse began tracking US data breaches in 2005

For more information, go to www.nrwa.org/affinity



DEFINE FLUSHABLE



**By Bill Thorson,
SDARWS Wastewater
Technician**

material is biodegradable or also known as organics. Items that are inorganics may include sand, grit, and minerals that can be dealt with mechanically in a wastewater system. Personal wipes do not break down and are of a material that resists being torn or cut and tends to plug or bind mechanical apparatuses. Wastewater systems have spent many thousands of dollars in dealing with personal wipes. Countless hours are spent clearing lift stations, pumps, baskets, screens, and blockages all due to issues with personal wipes. Pump repair or replacement is not an inexpensive budget item, especially when the pumps life expectancy is shortened exponentially.

One town is upgrading and rebuilding a lift station specifically to deal with the personal wipe problem. To save on repair costs and equipment failures, they have decided to put in a bar screen that will catch the personal wipes and other items not wanted in a wastewater system and remove them to a garbage dumpster before damage can occur to the pumps and valves. The system is being installed now, and as more info becomes available, it will be included in the next few articles. Stay tuned, as they say, for the rest of the story...◆

The items found in a wastewater system vary widely. Items vary by town, region, and even by state.

Coins, watches, shoes, bed sheets, toys, clothes, and rings are just a few of the items that have been found in a wastewater collection system. The only commonality is that most of the items are not actually “flushable”...

Now the rule of thumb is: if it has not been eaten or cannot be eaten, it should not go down the drain. The main exception to that rule is, of course, toilet paper. If you ask any wastewater system operator in South Dakota, “What is the worst thing you find in your system?” Invariably, the answer will be “Flushable wipes.” The flushable wipe is a personal hygiene cloth that is deemed on the package as “flushable.” It may say flushable, but the item is, however, not biodegradable. Therein lies the problem in a wastewater collection system, most “normal”





METER & AUTOMATION



NEPTUNE
TECHNOLOGY GROUP

FERGUSON[®]
WATERWORKS

Fargo

1917 1st Ave. N
(701) 293-5511

Bismarck

1201 Airport Rd.
(701) 258-9700

Blaine

1694 91st Ave. NE
(763) 560-5200

Find the closest waterworks location near you by visiting
FERGUSON.COM/WATERWORKS

©2017 Ferguson Enterprises, Inc. 0417 421536

hm Howalt+McDowell Insurance

MARSH & MCLENNAN
AGENCY



Commercial Insurance specializing in:

Agriculture | Construction | Healthcare | Hospitality
Manufacturing | Non-Profit | Retail/Wholesale | Rural Water

Personal Insurance specializing in:

Home | Car | Boat | RV | ATV | Umbrella

Life & Health Insurance specializing in:

Employee Benefits | Wellness | Consulting

300 N Cherapa Place 6th Floor
Sioux Falls, South Dakota
605 339-3874
www.howaltmcdowell.com

WORLD CLASS. LOCAL TOUCH.

WATER SYSTEM TAMPERING



**By Mike Moeller,
SDARWS Technical Assistance/
Training Specialist**

Everyone sees the signs that are hanging on fences around water plants and pump stations that state tampering with a water system is a federal offense. Most people probably look at them and think that it is just a scare tactic used by the water system to try to keep people away from their facilities. The truth of the matter is that tampering or even planning to tamper with a water system is, in fact, a federal offense that falls under statute 42 U. S. C. 300i – 1. The penalty for such actions is 20 years (10 if attempt or threat) and/or fines pursuant to 18 U. S. C. 3571.

Most of you reading this may be asking why I would be writing an article about this? The answer started a while back when I received a phone call from a water system on a Sunday morning about a leak they had in their system and may need my assistance finding it. I told the system that I would be available to assist them and to let me know if they needed me to come out and help. The manager for the system said they would try to track it down themselves first but ask that I keep my phone near me just in case. A few hours went by, and the manager called me back and had told me that they had started to isolate portions of the system

to try and figure out what area the leak would be in and had come across five of their mainline isolation valves that the bottom of the valve riser had been filled with concrete. I asked the manager if he had a contractor on the way because the only way to find the leak was to get those valves in working order. The manager said he did and just wanted to keep me up to date with what was going on if I had to assist them. More time had passed, and it was late afternoon, and the manager called me back again and said that a rancher had found the leak in his alfalfa field and they were in the process of getting the line shut down to do the repair. He thanked me for being available.

The next morning on my way to work I received a call from the manager again and asked me to stop by and see him and that he had something to show me. I told him I would, and when I arrived, I was shocked at what I saw. Along with the five valve risers with concrete, possibly the same person, had taken a steel fence post and removed what I call the spade portion of it, turned it around, so the two points were facing down and welded it back on to the post. The person then took the post and drove it into the ground until it penetrated the PVC water line creating the leak. The estimated water loss was 350,000 gallons not to mention the cost of excavating the leak and the five valve risers that needed to be fixed. The local sheriff's department was called in and the Region 8 EPA special investigation team was also made aware of the happenings.

In the end, the warning signs that are put on fences that state tampering or planning to tamper with a water system is a federal offense is stating the truth and not just a scare tactic. If you see someone doing such a thing help your water system out and let the authorities know. It will save everyone added costs. ♦



The photos pictured above left show the device that was used to damage the PVC water line (pictured) causing a 350,000 gallon leak.

You can order these warning signs online at www.waterprocommunity.org/page/all-items for just a few dollars. They are available in both plastic and aluminum.



Products & Services Portfolio

The Power of Association

Only the National Rural Water Association can bring together this unique Products and Services Portfolio. Choose from website design & customer communications, to several insurance packages including health plans, data breach services, line & leak coverage, background screening as well as our Rural Water Loan Fund, all designed to meet the needs of utilities.

Tap into the power of America's Largest Utility Membership!

Call **800.545.1054** for more information
or go to nrwa.org email: info@nrwa.org



NATIONAL RURAL WATER ASSOCIATION
NRWA *America's Largest Utility Membership*
Availability may be limited in some states.

IT MATTERS.

WATER. It grows our children and crops.
It develops our cities and country.
It powers our industries and businesses.
It cleanses our bodies and the land.

Providing water engineering and related services to help clients achieve success.

WATER ENGINEERING | CIVIL ENGINEERING | LAND SERVICES | SURVEY/MAPPING/GIS
MUNICIPAL FINANCIAL SERVICES | ASSET MANAGEMENT | INSTRUMENTATION & CONTROLS
ELECTRICAL ENGINEERING | STRUCTURAL ENGINEERING | COMMUNICATION SERVICES

THINK BIG. GO BEYOND.



Advanced Engineering and Environmental Services, Inc.
South Dakota Offices: Rapid City, Sioux Falls, Spearfish

www.ae2s.com

WaterPro[®]

Conference

HIGHLIGHTS



WHEN YOU
NEED POWER WE
ARE
THERE FOR YOU.

NEW OR USED, ANY SIZE OR SHAPE,
IN ANY REGULATORY ENVIRONMENT

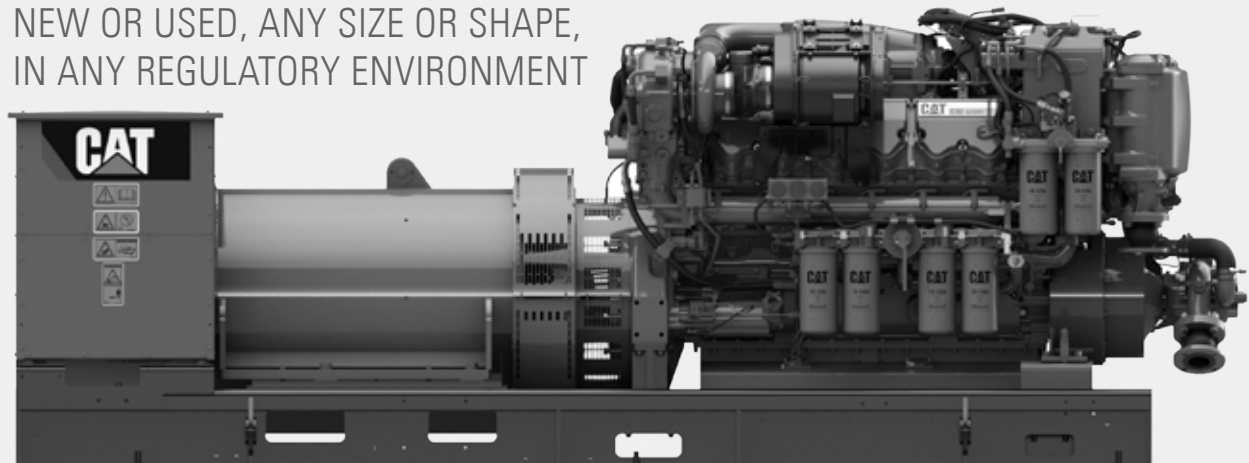

877.365.8114
BUTLERMACHINERY.COM

Butler 

QUICK & EASY FINANCING SOLUTIONS



www.cobank.com/h2oloan

844-846-3135

Proud Member of the Farm Credit System



NRWA AFFINITY PROGRAM SPOTLIGHT: IRIS MASS NOTIFICATION SYSTEM

TechRadium, Inc. is a leading provider of high-speed communication services to education institutions, corporations, non-profits and government entities worldwide. TechRadium gives organizations the ability to broadcast information via voice and text to thousands of people simultaneously with its easy-to-use mass notification service, IRIS (Immediate Response Information System).

BENEFITS

- Customizable web-based solution broadcasts messages simultaneously to multiple communication devices (landline, cell, email)
- Reduce mailing, printing, and labor costs by sending late pay and termination notifications, recover outstanding funds by routing customers to billing
- Maintain up-to-date customer data
- Intuitive interface allows for quick message creation and broadcasting
- Geographically targeted notifications can be used to contact residents in a specific area – with Call Center Support available 24/7/365
- Establish real-time conference calls, gathering the appropriate people in order to remedy the situation
- Improve customer relations by proactively delivering notices to a specified target audience during critical events
- Survey residents regarding customer's water quality and water pressure
- Multiple translation – over 20 languages offered.
- Customizable reports based on customer feedback
- Reduce inbound call volume using proactive messaging
- Enable staff to focus on more complex customer issues

- Streamline routine customer service, such as: payment notification, late payments, etc.
- Send time-sensitive information, such as boil water or contamination notices to affected residents on all devices, in minutes
- Prepare in advance for service interruption and maintenance and keep the public informed about water main breaks and repairs at their location
- Provide instructional information such as evacuation routes during an emergency
- Send messages regarding drought contingency plans and direct the public to your website
- Create customizable reports which can be helpful with local and state regulatory compliance requirements

ADDITIONAL FEATURES

- Severe Weather Advisories
- Homeowner infractions
- Evacuation instructions
- Water Contamination Notices
- Pipe Freeze Warnings
- Policy and Procedure Enforcement
- Employee Communication
- Billing and Payment Notifications
- Termination Notices
- No additional maintenance or training fees
- Using our API, our customers are able to integrate with external software applications, such as billing software or contact management applications

For more information on the IRIS mass notification system, visit www.useiris.com, call 1-866-270-0120, or email sales@useiris.com



STRUCTURE. & INTEGRITY.

PITTSBURGH TANK & TOWER GROUP

Since 1919



**CREWS
AVAILABLE
GLOBALLY**



[WWW.PTTG.COM](http://www.pttg.com)

INSPECTIONS REPAIR TANKS



Wet	Code	Elevated
Dry	Updates	Ground
ROV	Paint	Relocation
In-Service Cleaning	Insulation	Erection Dismantles

NEW TANKS – Rick DiZinno
(270) 826-9000 ext. 2601

EXISTING TANKS – Patrick Heltsley
(270) 826-9000 ext. 4601

MIDCONTINENT

TESTING LABORATORIES, INC.

- State-certified for **DRINKING WATER** and **WASTEWATER** testing
- Custom pre-printed sample forms save you time
- Setting the pace for analytical testing & customer service
- Our batch SOC testing can save you \$\$\$ in testing costs
- **FAST SERVICE!** Check your results online by logging on @ www.TheChemistryLab.com



2381 S. Plaza Drive P.O. Box 3388 Rapid City, SD 57709
Phone 605-348-0111 • FAX 605-721-0265

THEIN WELL

Over 100 Years of Service

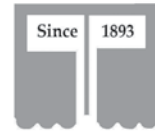

- Test/Production Wells
- Pump Sales/Service
- Well Rehabilitation
- Well Television
- Gamma/E-logging
- Well Abandonment
- Geo Probing
- Soil Borings
- Monitoring Well
- Remediation Wells
- Geothermal Systems
- Rock Coring



Certified Master
Groundwater Contractor

1-800-450-8000

www.theinwell.com

Bartlett & West

For over 60 years — engineering clean and safe water for our communities and for you.

&you

Water Engineering Services

- Preliminary, feasibility, and design reports
- Water source, treatment, and distribution design
- Long-range strategic and financial planning
- Regulatory compliance—strategies and planning
- GIS, GPS, and specialized system modeling
- Permitting, land rights, and easement management



5900 S WESTERN AVE, STE 101 ■ SIOUX FALLS SD ■ 605.274.7415 ■ BARTWEST.COM



**HOTEL ROOM BLOCK
AVAILABLE AT:**

**BEST WESTERN RAMKOTA
HOTEL**

PIERRE SOUTH DAKOTA
920 WEST SIOUX STREET
PIERRE, SOUTH DAKOTA 57501
605.224.6877

NEARBY HOTELS

CLUBHOUSE – 605.494.2582
DAYS INN – 605.224.0411
GOVERNOR’S INN – 605.224.4200

Association staff are busy getting ready for our Annual Leadership Seminar which will be held at the Best Western Ramkota Hotel in Pierre November 14-15th. This seminar is geared towards Rural Water System Directors and Board Members and includes informational sessions on parliamentary procedure, sustainable water systems, customer service, branding, Rural Development loans, augmented reality

GIS, economic development, and a leadership panel on strategic planning, rate management, and productive meetings. The cost to attend Leadership is \$160, and includes a meal at the President’s Reception on the evening of November 14th. There will be a \$15 discount for WaterPro members. Registration for this event will be available on our website at sdarws.com. The tentative agenda is below:

Wednesday – November 14

- 1:00 WELCOME** – *Ron Gillen, President, SDARWS*
PLEDGE OF ALLEGIANCE
AGENDA REVIEW
- 1:15 PARTNERS FOR FINANCIAL RESOURCES**
*Todd Keyes – 1st Planning District,
Executive Director*
- 2:00 CYBER SECURITY AWARENESS**
Buzz Hillestad – SBS, Sr. Security Consultant
- 3:00 BREAK**
- 3:15 MISSOURI RIVER MAINSTEM
SEDIMENTATION ISSUES**
Tim Cowman – State Geologist
- 4:00 BREAK**
- 4:15 FIDUCIARY RESPONSIBILITY**
*Margo Northrup - Riter, Rogers, Wattier,
& Northrup, LLP*
- 5:30 PRESIDENT’S RECEPTION**
- 6:00 DINNER & GUEST SPEAKER**
*Edna Primrose – Rural Development
WEP Administrator*

Thursday – November 15

- 8:00 PARLIAMENTARY PROCEDURE**
Dr. Nancy Moose
- 8:45 BREAK**
- 9:00 GRASSROOTS SUPPORT: THE NRWA
LEGISLATIVE APPROACH**
*Bill Simpson, Michael Preston & Mike
Keegan – NRWA (via Skype)*
- 10:00 BREAK**
- 10:15 LEADERSHIP: INSTILLING COMMUNITY
TRUST IN YOUR WATER SYSTEM**
Erin Dreis – SD DENR
- 10:45 POLICY UPDATE: SOUTH DAKOTA TO
WASHINGTON D.C.**
*Lynn Tjeerdsma - Senior Policy Advisor
for Senator John Thune*
- 11:30 CLOSING COMMENTS**
Ron Gillen

**This is a tentative agenda and is subject to change*

Thompson Knows Controls & Automation



SYSTEM DESIGN & ENGINEERING



SCADA/HMI SYSTEMS DEVELOPMENT



UL CERTIFIED CUSTOM CONTROL PANEL FABRICATION



MAINTENANCE SERVICE HARDWARE/PROGRAMMING



Thompson
Automation and
Specialty Services



thompsonspecialty.com

844.321.3869

PHOTOS FROM THE FIELD



SDARWS Exercise program (or maybe it's just Wastewater Tech Bill Thorson and Safety Trainer Steve Attema sludge judging a lagoon)



Circuit Rider Greg Gross exercising valves in Chancellor.



HydroKlean pipeline and manhole rehabilitation class in Wessington Springs.



Wastewater Tech Bill Thorson and Circuit Rider Nick Jackson assisting BIA with lift station safety and maintenance training in Pine Ridge.

To see more pictures of SDARWS in action, follow us on Facebook
www.facebook.com/SDRuralWater

CERTIFICATION PRACTICE QUESTIONS

1 SIMULATING A WATER PLANTS COAGULATION AND FLOCCULATION PROCESSES IN THE LAB WITH DIFFERENT CHEMICAL DOSAGES IS ANOTHER TERM FOR?

- a. Titration
- b. Hardness Test
- c. Jar Test
- d. Chlorine Test

2 THE SLOW STIRRING PROCESS THAT CAUSES THE GATHERING TOGETHER OF SMALL PARTICLES INTO LARGE SETTLEABLE PARTICLES IS CALLED?

- a. Coagulation
- b. Flocculation
- c. Sedimentation
- d. Flash Mixing

3 WATER MOVING FASTER THROUGH A FLOCCULATION BASIN THAN THE REST OF THE WATER IS FLOWING IS CREATING A CONDITION KNOWN AS?

- a. Rapid Mixing
- b. Non-settling
- c. Short-circuiting
- d. Mass Molecular Movement

4 BY DECREASING THE VELOCITY OF THE WATER BEING TREATED, THUS ALLOWING TIME FOR GRAVITY FORCES TO REMOVE PARTICLES HELD IN SUSPENSION IS CALLED?

- a. Filtration
- b. Coagulation
- c. Flocculation
- d. Sedimentation

5 TUBE SETTLERS PROVIDE A HIGH RATION OF EFFECTIVE SETTLING SURFACE AREA PER UNIT VOLUME OF WATER. EACH TUBE FUNCTIONS AS A SHALLOW:

- a. Settling Basin
- b. Filter
- c. Flocculator
- d. All of the above

6 THE ACTUAL TIME REQUIRED FOR A SMALL AMOUNT OF WATER TO PASS THROUGH A BASIN AT A GIVEN RATE OF FLOW IS A GOOD DEFINITION OF?

- a. rate of flow
- b. plant run time
- c. contact time
- d. detention time

7 SOLIDS-CONTACT UNITS COMBINE THE FOLLOWING TREATMENT PROCESSES:

- a. flocculation/sedimentation
- b. coagulation/sedimentation
- c. filtration/sedimentation
- d. coagulation/flocculation/sedimentation

8 MOST OF THE PARTICLES REMOVED DURING FILTRATION ARE CONSIDERABLY _____ THAN THE PORE SPACES IN THE MEDIA.

- a. Larger
- b. Smaller

9 GRAVITY FILTRATION WILL REMOVE?

- a. dissolved solids
- b. alkalinity
- c. hardness
- d. suspended solids

10 BACKWASHING FILTERS IS THE SIMPLE PROCESS OF REVERSING THE FLOW OF WATER THROUGH THE FILTER TO ALLOW TRAPPED PARTICLES TO BE FLUSHED OUT TO WASTE. THE RECOMMENDED BACKWASH RATE IS?

- a. 2-4 gpm/square foot
- b. 6-8 gpm/square foot
- c. 12-15 gpm/square foot
- d. 20-25 gpm/square foot

A SUPERIOR WEBSITE FOR YOUR TOWN OR WATER SYSTEM IS NOW EASY & AFFORDABLE!

Municipal Impact and Rural Water Impact provide beautiful, mobile-friendly websites for towns and Water Systems – all at a very affordable price. Kick back while we do all the work and setup, then make updates yourself anytime you want. Secure hosting and unlimited support are included, too. You'll never hire an expensive web designer again!



MunicipalImpact.com
Smart Websites for Smart Communities™



RuralWaterImpact.com
Smart Websites for Smart Water Systems™



“We’re the Website People!”

For pricing and information, visit us online at www.municipalimpact.com or www.ruralwaterimpact.com
Or call us today at 1.800.551.4815.





FROM THE EXECUTIVE DIRECTOR

KURT PFEIFLE, EXECUTIVE DIRECTOR

South Dakota Association of Rural Water Systems (SDARWS) is pleased to announce the hiring of Abbey Larson as the new Wastewater Technician II. The new position will be stationed in our west river office in Spearfish, SD. Abbey has already found living quarters in Spearfish and has begun settling into her new home. Abbey has a B.S. Degree in Civil Engineering from the South Dakota School of Mines and Technology. She had been working for South Dakota Department of Environment & Natural Resources as a “Natural Resources Engineer I” in Pierre, SD. Abbey’s first day with SDARWS was Monday, October 1, 2018. Following a day of introductions and paperwork, she spent a good share of her first week with SDARWS’s other Wastewater Technician, Bill Thorson for orientation and work scheduling.

SDARWS received the news on July 2, 2018 that our Association would be receiving a new Wastewater Technical Assistance & Training (TAT) position. National Rural Water Association (NRWA) contacted Executive Director Pfeifle and followed up with an email stating that the NRWA Executive Committee approved budget adjustments and expansion of positions for the USDA Wastewater and Energy Efficiency programs. Overall 14 new positions were created nationwide, including seven wastewater technicians and seven Energy Efficiency positions:

■ **Seven positions were added to the USDA Wastewater Training & Technical Assistance program:**

MT, OR, KS, CO, SD, AZ, VA

■ **Seven positions were added to the USDA Energy Efficiency program:**

FL, IL, WI, IN, PA, MN, NC

The new Wastewater Technician position will be funded through USDA – Rural Development, through a subaward contract with NRWA. The new position comes to SDARWS with a Program allocation of \$115,000 per year. The allocation provides direct funding for salary, benefits, travel, training materials and funding for certain indirect costs (share of expenses that keep the business running) to SDARWS.

Please join us in welcoming Abbey Larson to the SDARWS team! ♦



Abbey Larson
West River Wastewater Technician



NRWATM



**IN 1929, AMERICAN
INVENTED THE MECHANICAL JOINT.
TODAY WE BRING YOU ALPHA™.**

Few things in the waterworks industry have been as innovative as the Mechanical Joint. Times have changed. And so has AMERICAN. Introducing the AMERICAN Flow Control Series 2500 with ALPHA™ ends. Now, you can use the same valve for ductile iron, HDPE, PVC, and even cast iron pipe. Unlike MJ, the restraint accessories come attached, leaving only one bolt on each end to tighten. That saves you time and money.

The AMERICAN Series 2500 with ALPHA™ ends – it's the only gate valve you'll ever need.

ALMOST ANY MATERIAL.
NO TIME AT ALL.



AMERICAN
FLOW CONTROL
THE RIGHT WAY

www.american-usa.com
PO Box 2727, Birmingham, AL 35207 • Ph: 1-800-326-8051 • Fx: 1-800-610-3569
EOE/Vets/Disabilites
ALPHA™ is a trademark of Romac Industries Inc. (U.S. Patent 8,894,100)

DUCTILE IRON PIPE FLOW CONTROL INTERNATIONAL SPIRALWELD PIPE STEEL PIPE

***When It Comes
To Waterworks,
There Can Be
A Lot Of Pressure.***



WATERWORKS



To succeed, you need a partner that makes your job easier. With Dakota Supply Group, you get more than just pipe and products:

- ▶ Contact us today to learn more about how we can help you.

DSG
DAKOTA SUPPLY GROUP
For all the right connections!

FARGO, ND ▶ [800] 342-4676
BISMARCK, ND ▶ [855] 337-9258
SIOUX FALLS, SD ▶ [800] 660-5531
RAPID CITY, SD ▶ [800] 660-5538
BURNSVILLE, MN ▶ [800] 325-0514

www.dakotasupplygroup.com



South Dakota Rural Water

203 W. Center Street

P.O. Box 287

Madison, SD 57042

www.sdarws.com



HRGreen®



Providing water and wastewater services for more than a century.

▷ 431 N. Phillips Ave, Suite 400
Sioux Falls, South Dakota 57104-5933
Phone 605.334.4499

▷ HRGREEN.COM

TRANSPORTATION + WATER + GOVERNMENTAL SERVICES
LAND DEVELOPMENT + ENVIRONMENTAL + CONSTRUCTION